

# SB5 beam load cell

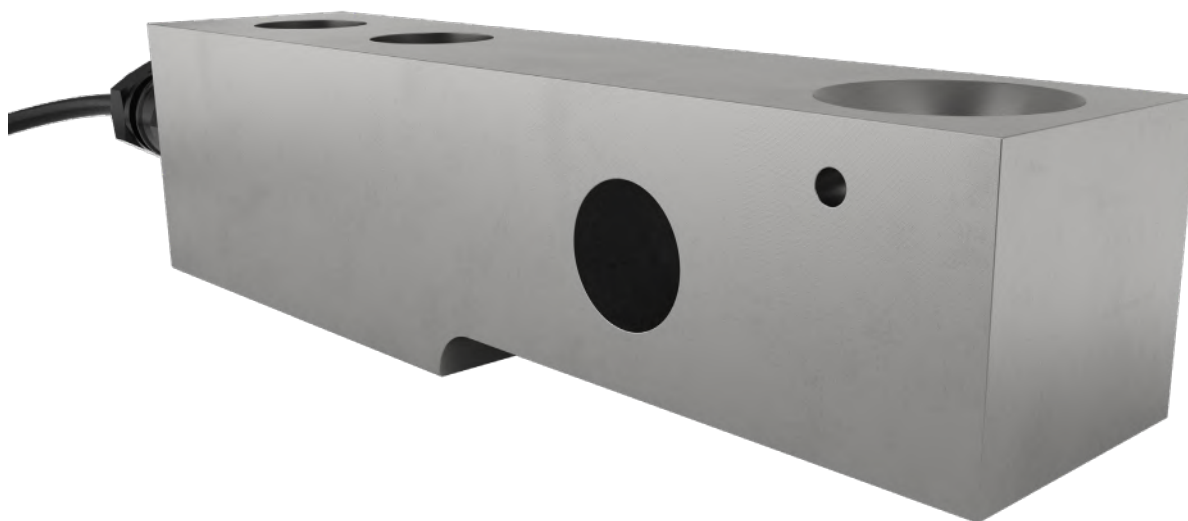

## product description

The SB5 is a highly accurate, low profile, bending beam load cell; available in a wide range of capacities. Full stainless steel construction combined with high performance potting ensures reliable accuracy and robustness in harsh industrial applications where fully hermetic sealing is not required. The SB5 is the ideal choice for high accuracy weighing platforms due to the blind-hole load introduction arrangement combined with the self-aligning feet. Fully interchangeable with the hermetically sealed SB4.

## applications

Industrial platform scales, pallet truck scales, vessel and tank weighing systems.

## key features

Stainless steel construction with low profile design

Environmentally sealed by potting to IP67

Wide range of capacities from 5kN to 100kN (510kg to 10,197kg)

High accuracy, high input resistance

Unique blind loading hole

Calibration in mV/V/Ω



RoHS  
compliant



## approvals

OIML approval to C1 (Y = 5,100) and C3 (Y = 11,000), for 5 ...50kN models only

NTEP approval to 5,000 intervals, Class III (for 5kN to 50kN) for multiple load cells

ATEX hazardous area approval for zones 0, 1, 2, 20, 21 and 22

FM hazardous area approval

## accessories

Compatible range of hardware

Compatible range of electronics

## specifications

Maximum capacity ( $E_{max}$ )	kN	5 / 10 / 20 / 50 / 100	5 / 10 / 20 / 50	
Metric equivalents (1 N=0.10197 kg)	kg	510 / 1,020 / 2,039 / 5,099 / 10,197	510 / 1,020 / 2,039 / 5,099	
Accuracy class according to OIML R60		(GP)	C1	C3
Maximum number of verification intervals ( $n_{max}$ )		n.a.	1,000	3,000
Minimum load cell verification interval ( $v_{min}$ )		n.a.	$E_{max}/5,100$	$E_{max}/11,000$
Temperature effect on minimum dead load output ( $TC_0$ )	%*RO/10°C	± 0.0400	± 0.0275	± 0.0127
Temperature effect on sensitivity ( $TC_{RO}$ )	%*RO/10°C	± 0.0200	± 0.0160	± 0.0100
Combined error	%*RO	± 0.0500	± 0.0300	± 0.0200
Non-linearity	%*RO	± 0.0400	± 0.0300	± 0.0166
Hysteresis	%*RO	± 0.0400	± 0.0300	± 0.0166
Creep error (30 minutes) / DR	%*RO	± 0.0600	± 0.0490	± 0.0166
Rated Output (RO)	mV/V	2 ± 0.1%		
Calibration in mV/V/ (A...I classified)	%	± 0.05 (± 0.005)		
Zero balance	%*RO	± 5		
Excitation voltage	V	5...15		
Input resistance ( $R_{LC}$ )	Ω	1,100 ± 50		
Output resistance ( $R_{out}$ )	Ω	1,000 ± 2		
Insulation resistance (100 V DC)	MΩ	≥ 5,000		
Safe load limit ( $E_{lim}$ )	%* $E_{max}$	200		
Ultimate load	%* $E_{max}$	300		
Safe side load	%* $E_{max}$	100		
Compensated temperature range	°C	-10...+40		
Operating temperature range	°C	-20...+65 (ATEX -20...+60)		
Load cell material		stainless steel 17-4 PH (1.4548)		
Sealing		potted		
Protection according to EN 60 529		IP67		
Packet weight	kg	1.4 (5-20kN), 2.9 (50kN), 7.0 (100kN)		

The limits for Non-Linearity, Hysteresis, and  $TC_{RO}$  are typical values. The sum of Non-linearity, Hysteresis and  $TC_{RO}$  meets the requirements according to OIML R60 with  $pLC=0.7$ .

## product dimensions (mm)

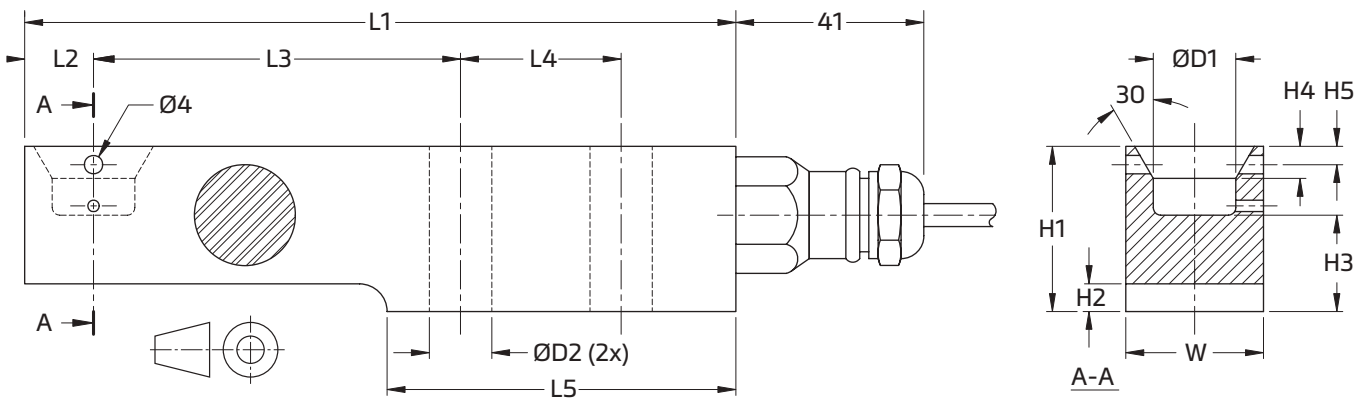

\*\*As it has in no way influence on the functionality and accuracy of the load cell, this dimension might be in singular cases shorter.

Type	L1	L2	L3	L4	L5	H1	H2	H3	H4	H5	W	D1	D2	Mounting bolts	Torque *
SB5-5 kN/10 kN/20 kN	155	15	80	35	76	36	6	21	7	4	30	18	13	M12 8.8	90 Nm
SB5-50 kN	190	21	105	40	93	49	8	28.5	6	8	43	25	21	M20 8.8	400 Nm
SB5-100 kN	245	30	135	50	120	73	12.5	42	10	n.a.	60	30	27	M24 8.8	700 Nm

\* Torque values assume oiled threads.

## wiring

The load cell is provided with a shielded, 4 conductor cable (AWG 24).

Cable jacket: polyurethane

Cable length: 3 m for SB5-5 kN/10 kN/20 kN  
4.5 m for SB5-50 kN/100 kN

Cable diameter: 5 mm

The shield is floating  
(On request the shield can be connected to the load cell body)

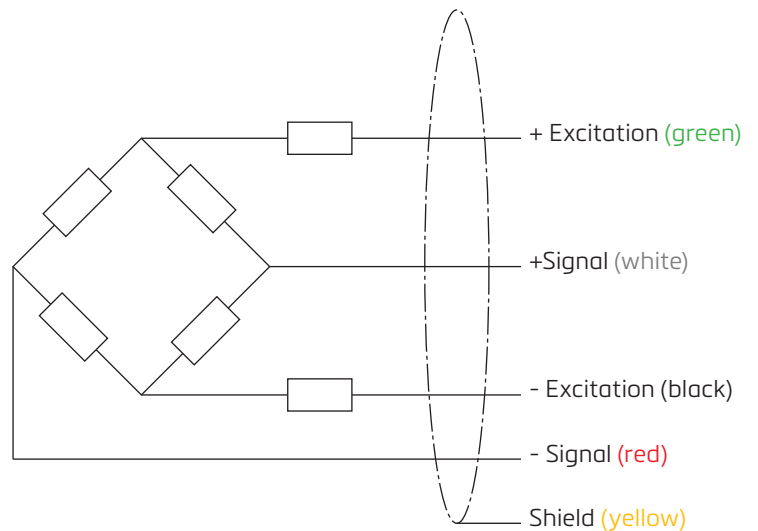

Specifications and dimensions are subject to change without notice.