

PCB single point load cell

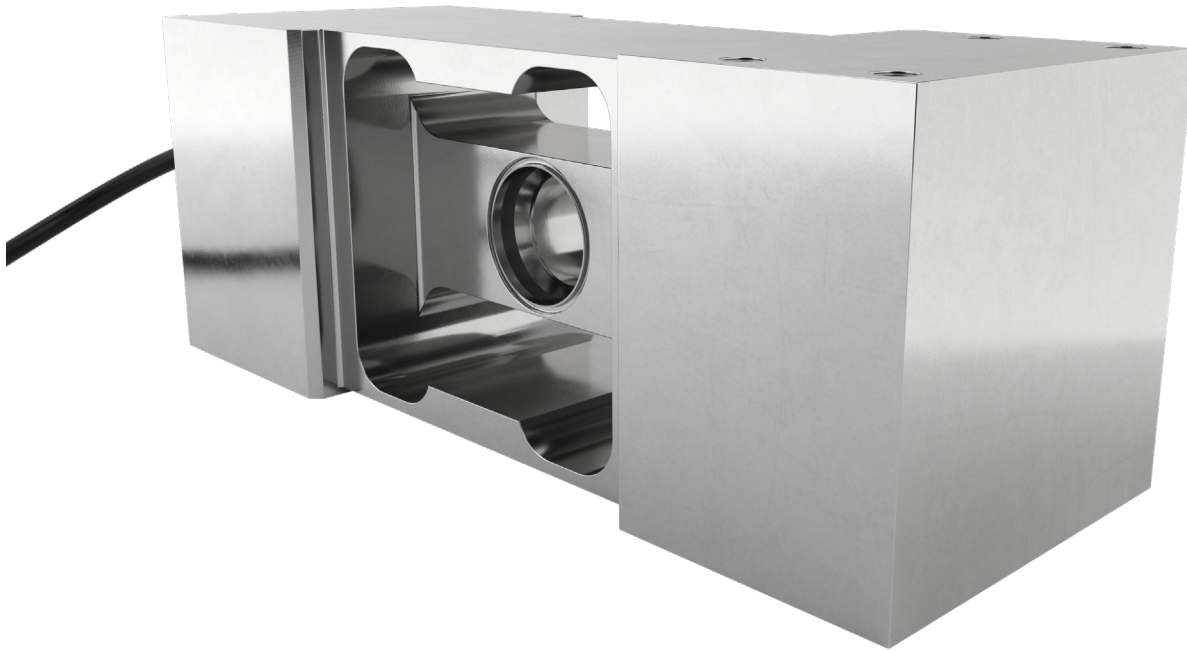

product description

The PCB single point load cell is the high capacity end of the hermetically sealed load cell range from Flintec. Providing all of the high accuracy performance for trade approved weighing scales but available in a wide range of capacities from 50kg through to 1T – all in one sensor body size. Full stainless-steel construction ensure the PCB load cell is capable of surviving the tough environments in food and chemical processing applications.

applications

Bench and platform scales, high-speed checkweighers, marine scales, multi-head weighers.

key features

Stainless steel construction, hermetically sealed to IP68

For platform sizes of up to 1,000 x 1,000mm

High accuracy, high input resistance

Wide range of capacities from 50kg to 1,000kg

Integral mounting spacer

approvals

OIML approval to C3 and C3 MI6
(Y = 12,500)

NTEP approval to 5,000 intervals,
Class III

ATEX hazardous area approval for
zones 0, 1, 2, 20, 21 and 22

FM hazardous area approval

accessories + options

Compatible range of electronics

Y = 20,000 for C3 and C3 MI6

Y = 25,000 for C3 and C3 MI6 (for
250kg or higher capacities)



RoHS
compliant



 **flintec**
quality + precision

specifications

Maximum capacity (E_{max})	kg	50 / 100 / 250 / 500 / 1,000		
Accuracy class according to OIML R60		(GP)	C3	C3 MI 6
Maximum number of verification intervals (n_{LC})		n.a.	3,000	
Minimum load cell verification interval (v_{min})		n.a.	$E_{max} / 12,500$	
Temperature effect on minimum dead load output (TC_0)	%*RO/10°C	± 0.0400	± 0.0112	
Temperature effect on sensitivity (TC_{RO})	%*RO/10°C	± 0.0200	± 0.0100	
Combined error	%*RO	± 0.0500	± 0.0200	± 0.0180
Non-linearity	%*RO	± 0.0400	± 0.0166	± 0.0166
Hysteresis	%*RO	± 0.0400	± 0.0166	± 0.0083
Creep error (30 minutes) / DR	%*RO	± 0.0600	± 0.0166	± 0.0083
Optional: Min. load cell verification interval ($v_{min opt}$)		n.a.	$E_{max} / 20,000$; 250 kg or higher: $E_{max} / 25,000$	
Optional: Temp. effect on min. dead load output ($TC_0 opt$)	%*RO/10°C	n.a.	± 0.0070; 250 kg or higher: ± 0.0056	
Rated Output (RO)	mV/V	2 ± 5%		
Zero balance	%*RO	± 5		
Excitation voltage	V	5...15		
Input resistance (R_{LC})	Ω	1100 ± 50		
Output resistance (R_{out})	Ω	960 ± 50		
Insulation resistance (100 V DC)	MΩ	≥ 5000		
Safe load limit (E_{lim})	%* E_{max}	200		
Ultimate load	%* E_{max}	300		
Safe side load	%* E_{max}	100		
Maximum platform size; loading acc. to OIML R76	mm	600 x 600 for 50 kg / 800 x 800 for 100 kg / 1,000 x 1,000 for 250...1,000 kg		
Maximum off centre distance at maximum capacity	mm	200 for 50 kg / 250 for 100...500 kg / 300 for 1,000 kg		
Compensated temperature range	°C	-10...+40		
Operating temperature range	°C	-40...+80 (ATEX -40...+60)		
Load cell material		stainless steel 17-4 PH (1.4548)		
Sealing		complete hermetic sealing; cable entry sealed by glass to metal header		
Protection according EN 60 529		IP68 (up to 2 m water depth) / IP69K		
Packet weight	kg	5.4 (50-100kg), 5.7 (250-500kg), 5.8 (1,000kg)		

The limits for Non-Linearity, Hysteresis, and TC_{RO} are typical values.

The sum of Non-linearity, Hysteresis and TC_{RO} meets the requirements according to OIML R60 with $p_{LC}=0.7$.

product dimensions (mm)

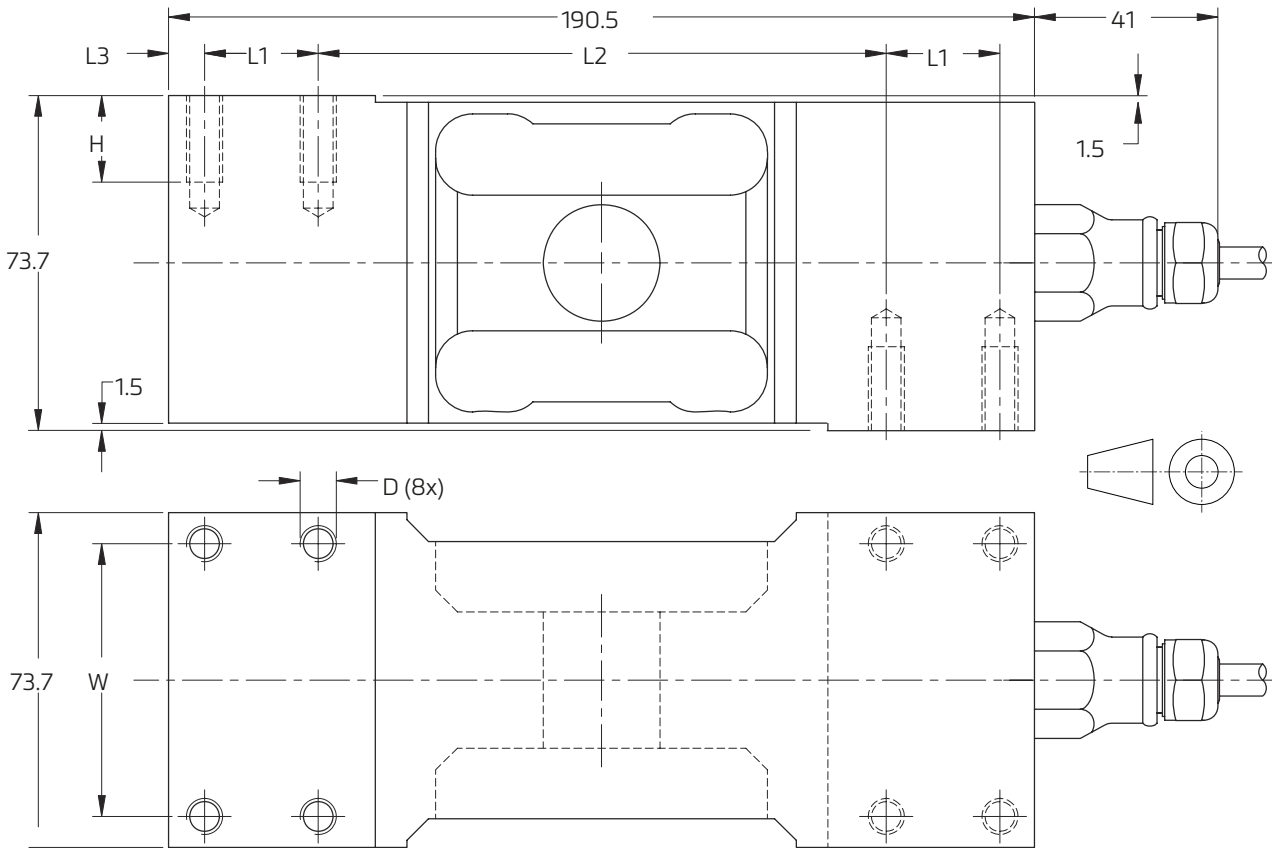

Type	L1	L2	L3	H	W	D	Mounting bolts	Torque 1)
PCB-50/100/250/500/1,000 kg	25	125	8	19	60	M8 2)	M8 8.8 / PCB-1,000 kg: M8 12.9	25 Nm
PCBB-500/1,000 kg	35	104,5	8	25	57	M12	M12 8.8	90 Nm
PCBC-50/100/250/500/1,000 kg	35	107	6.75	19	50	M8 2) 3)	M8 8.8	25 Nm

1) Torque values assume oiled thread. 2) Unified thread 5/16-18 is available. 3) OIML approval only valid for M8 threads.

wiring

The load cell is provided with a shielded, 6 conductor cable (AWG 26) or with a shielded, 4 conductor cable (AWG 24).

Cable jacket: polyurethane.

Cable length: 3 m

Cable diameter: 5 mm

The shield is floating or connected to the load cell body

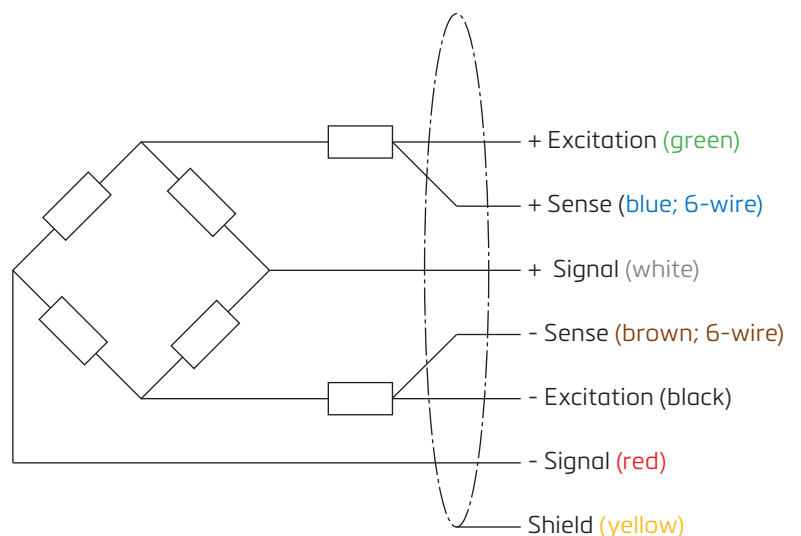

Specifications and dimensions are subject to change without notice.