

CN3 bending ring load cell



product description

The CN3 is a compression load cell with a bending ring design. It delivers high-accuracy measurements across a wide range of high-capacity models.

It is constructed from stainless steel and is fully welded to ensure complete environmental protection. It has a compact and low-profile design.

Certified to both OIML and NTEP requirements, the CN3 is an ideal choice for trade-approved applications, such as tanks, silos and high-capacity platform scales. ATEX approval is pending, and assures that the CN3 is a safe and reliable choice for use in explosive and volatile environments.

The CN3 comes preconfigured and assembled in custom mounting to ensure optimum performance. Alternatively, the load cell is available without the mount.

available options

CN3 pre-assembled in its mount (CN3 Weigh Point)

CN3 load cell only (CN3 sensor only)

applications

Process Automation and Control & Process Weighing.

key features

Capacities from 500kg to 10T

All stainless-steel construction

Hermetically sealed to IP68/IP69K

Compact & low-profile design

OIML approval to C3 and C4

NTEP approval to Class III 5,000 and Class III L 10,000

ATEX approval

Electro-polished surface for clean environments

FM approval pending

accessories

Compatible range of electronics



RoHS
compliant



pending



 **flintec**
quality + precision

specifications

Maximum capacity (E_{max})	kg	500	1,000 / 2,000 / 5,000 / 10,000
Minimum dead load	kg	0	
Accuracy Class	-	C3	C4
Rated Output	mV/V	2.0 ± 0.1 mV	
Maximum number of load cell intervals	n	3,000	4,000
Ratio of minimum LC Verification interval ($Y = E_{max} / v_{min}$)	-	15,000	
Ratio of minimum dead load output return ($Z = E_{max} / (2 * DR)$)	-	5,100	6,000
Temperature effect on min. dead load output (TCO)	%RO/10 °C	±0.0093	
Temperature effect on sensitivity (TC_{r0})	%RO/10 °C	± 0.0100	±0.0080
Combined error	%RO	± 0.0200	±0.0180
Non-linearity	%RO	± 0.0166	±0.0125
Hysteresis	%RO	± 0.0166	±0.0125
Creep error (30 min)/DR	%RO	± 0.0166	±0.0125
Input impedance	Ω	1050 ±50Ω	
Output impedance	Ω	1020 ±60Ω	
Temperature range	°C	-10...+ 40	
Fraction p_{LC}	-	0.7	
Safe overload	% of E_{max}	200	
Recommended excitation	V AC / DC	10	
Excitation maximum	V AC / DC	15	
Transducer material	-	Stainless steel	
Atmospheric protection	-	Hermetically welded	

product dimensions (pre-assembled in mount) (mm)

Final Installation

Top-down View

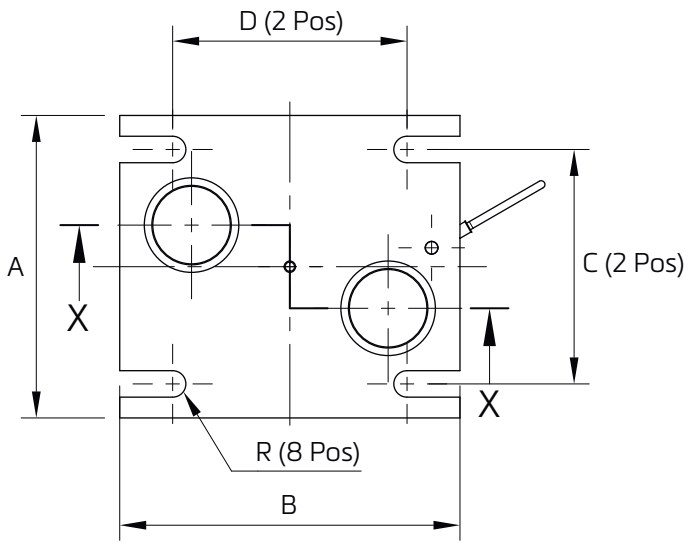

Front View

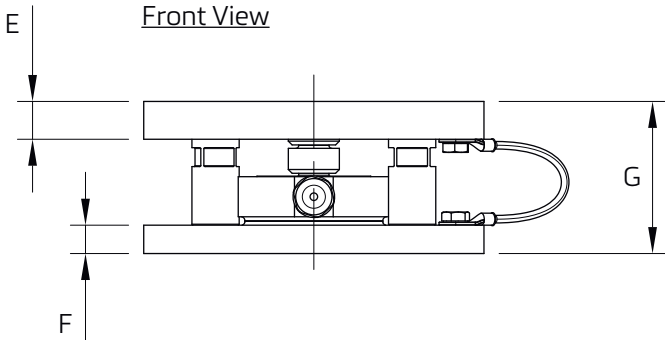

Section X-X

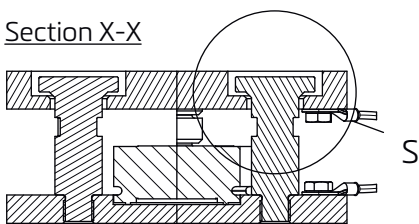

Detail S (2:1)

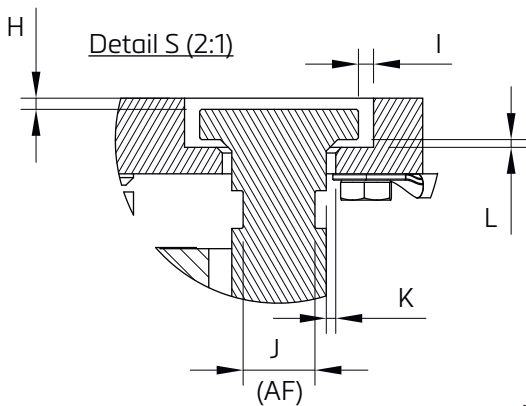

Pre Installation

Top-down View

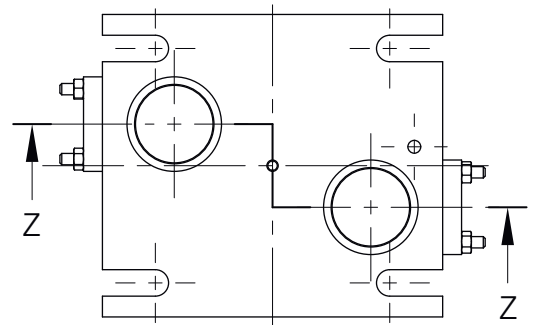

Front View

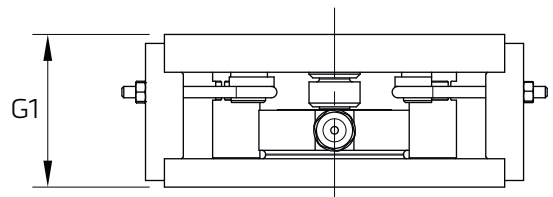

Section Z-Z

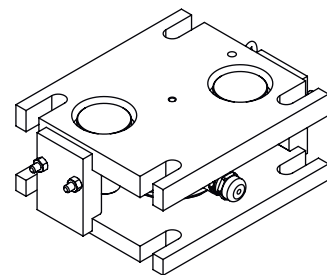
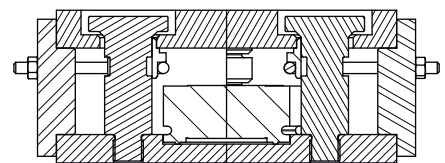

Note: The mounted 1,000kg CN3 is illustrated.

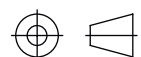

product dimensions cont.

Capacity (kg)	A (mm)	B (mm)	C (mm)	D (mm)	E (mm)	F (mm)	G (mm)
500	140.0	120.0	100.0	100.0	15.00	10.0	67.45
1,000	160.0	180.0	124.0	124.0	20.00	15.0	80.45
2,000	160.0	180.0	124.0	124.0	20.00	15.0	90.45
5,000	160.0	180.0	124.0	124.0	20.00	15.0	101.45
10,000	180.0	200.0	140.0	140.0	30.00	20.0	140.45

Capacity (kg)	G1 (mm)	H (mm)	I (mm)	J (mm)	K (mm)	L (mm)	R (mm)
500	67.75	1.5	2.5	13.0	1.5	1.5	7.0 (M12)
1,000	80.75	3.0	4.0	19.0	2.5	2.05	7.0 (M12)
2,000	90.75	2.5	4.0	19.0	3.0	2.55	7.0 (M12)
5,000	101.75	2.5	4.0	19.0	3.0	2.55	7.0 (M12)
10,000	140.75	2.5	5.0	19.0	4.0	3.05	9.0 (M16)

specifications for the mounted sensor

Load cell capacity	kg	500	1,000	2,000	5,000	10,000
Max lift-off force	kg	500	2,000	2,000	2,000	5,000
Max side-load	kg	300	800	800	800	750
Plate material	-	stainless steel 304				
Pins material	-	stainless steel 17-4PH				
Additional parts material	-	zinc plated plain carbon steel (mild steel)				

mount features

Built-in lift off

Earth strap

Shipping stops

Anti-rotation

Stainless steel construction

sensor body dimensions (mm)

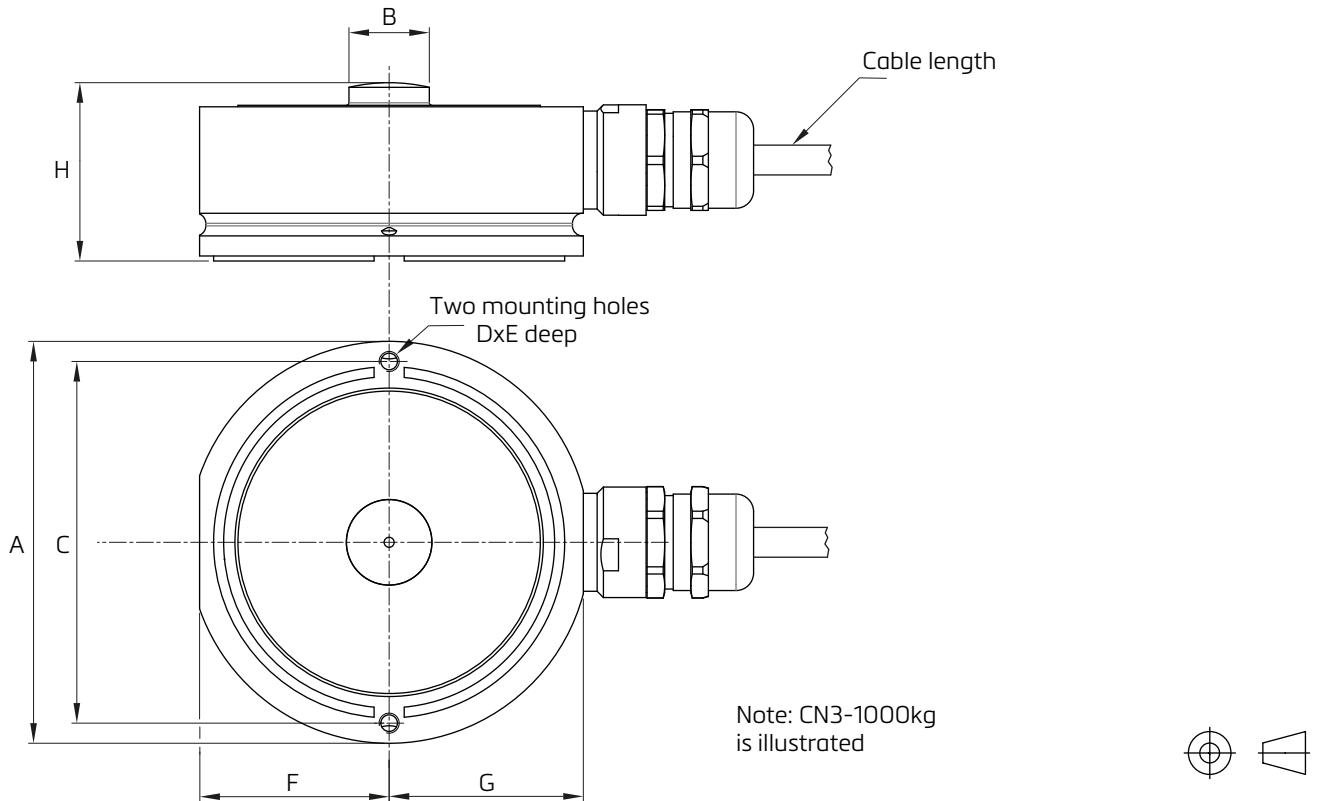

Capacity (kg)	H (mm)	A (mm)	B (mm)	C (mm)	Thread D	E (mm)	F (mm)	G (mm)	Cable length (m)
500	36	60	8	52	M4	3	26.9	28.1	3
1,000	35.5	80	16	72	M4	4	37.7	38.7	3
2,000	40.5	80	16	72	M4	4	37.7	38.7	5
5,000	40.5	80	16	72	M4	4	37.7	38.7	5
10,000	47.0	95	29	86.5	M5	8	45.4	46.2	5

wiring

Six individual conductors of 26 AWG tinned copper with drain wire

Insulation : TPM, 0.3mm thickness

Wrapping : Aluminated polyester wrap

Sheath: Material TPM, 0.75mm thickness

Cable length: See dimensions table.

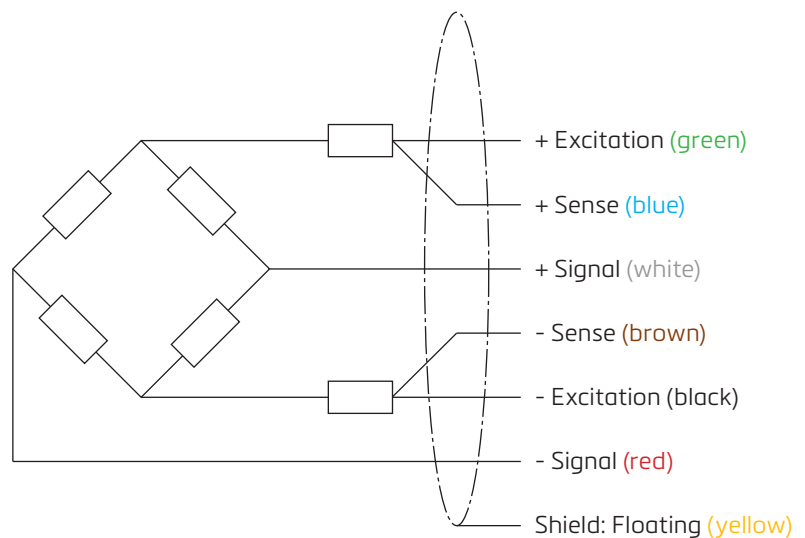

Specifications and dimensions are subject to change without notice.