

BK2 beam load cell

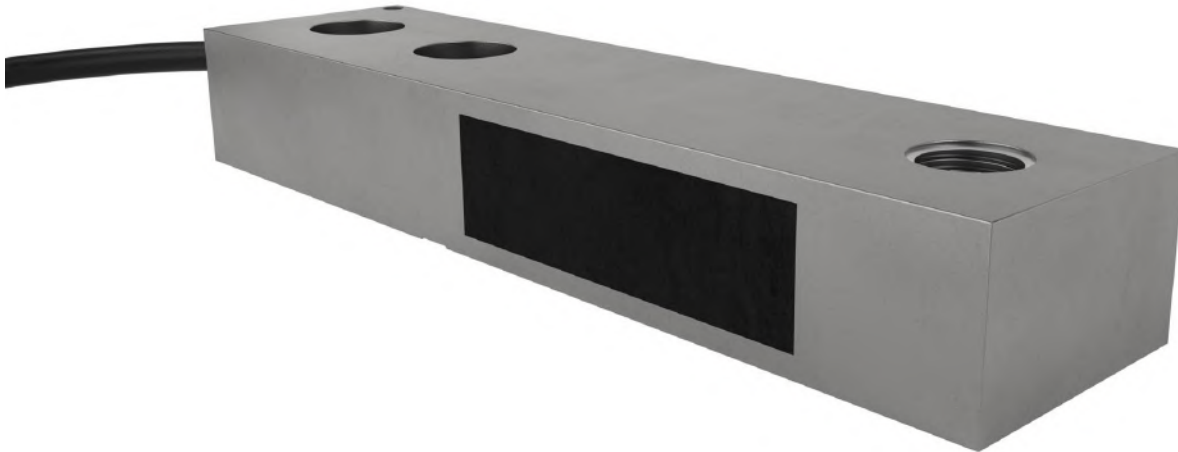

product description

Designed for use in low profile or space restrictive industrial and medical weighing applications. The BK2 range of shear beam load cells are designed to withstand harsh industrial operation whilst offering trade approved levels of accuracy, certified to OIML and NTEP standards.

applications

Platform weighing machines, pallet truck scales, tank and vessel weighing systems, conveyor scales and patient weighing systems such as intensive care beds and wheelchair scales

key features

Stainless steel construction

Environmentally sealed by potting

Low profile

Wide range of capacities

approvals

OIML approval to C3 (Y = 10,000) for the 500, 1,000 and 2,000kg models

NTEP class III approval to 5,000 intervals for multiple load cell applications

ATEX hazardous area approval for zones 0, 1, 2, 20, 21 and 22

FM hazardous area approval

accessories + options

Compatible range of hardware

Compatible range of electronics

Metric or unified threads available



RoHS
compliant



specifications

Maximum capacity (E_{max})	kg	200 / 500 / 1,000 / 2,000	500 / 1,000 / 2,000
Accuracy class according to OIML R60		(GP)	C3
Maximum number of verification intervals (n_{max})		n.a.	3,000
Minimum load cell verification interval (v_{min})		n.a.	$E_{max} / 10,000$
Temperature effect on minimum dead load output (TC_0)	%*RO/10°C	± 0.0400	± 0.0140
Temperature effect on sensitivity (TC_{RO})	%*RO/10°C	± 0.0200	± 0.0100
Combined error	%*RO	± 0.0500	± 0.0200
Non-linearity	%*RO	± 0.0400	± 0.0166
Hysteresis	%*RO	± 0.0400	± 0.0166
Creep error (30 minutes) / DR	%*RO	± 0.0600	± 0.0166
Rated Output (RO)	mV/V	2 ± 0.1%	
Calibration in mV/V/Ω (A...I classified)	%	± 0.05 (± 0.005)	
Zero balance	%*RO	± 5	
Excitation voltage	V	5...15	
Input resistance (R_{LC})	Ω	1,100 ± 50	
Output resistance (R_{out})	Ω	1,000 ± 2	
Insulation resistance (100 V DC)	MΩ	≥ 5,000	
Safe load limit (E_{lim})	%*E _{max}	200	
Ultimate load	%*E _{max}	300	
Safe side load	%*E _{max}	100	
Compensated temperature range	°C	-10...+40	
Operating temperature range	°C	-20...+65 (ATEX -20...+60)	
Load cell material		stainless steel 17-4 PH (1.4548)	
Sealing		potted	
Protection according EN 60 529		IP67	
Packet weight	kg	0.67 (200kg), 0.74 (500kg), 0.82 (1,000kg), 0.99 (2,000kg)	

The limits for Non-Linearity, Hysteresis, and TCRO are typical values. The sum of Non-linearity, Hysteresis and TCRO meets the requirements according to OIML R60 with pLC=0.7.

product dimensions (mm)

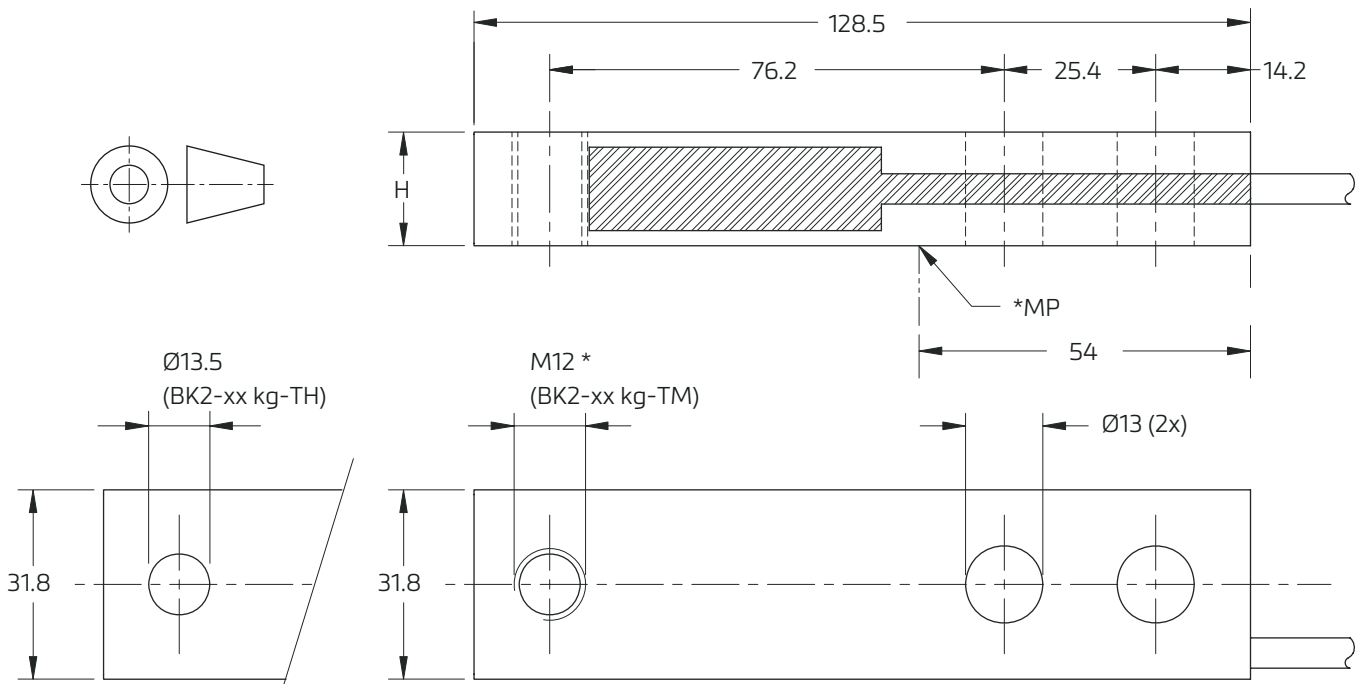

*MP – Edge of mounting plate

Unified thread ½-20 UNF is available (product code: BK2-xx kg-TU-Cx)

type	H	mounting bolts	torque**
BK2-200 kg	12.7	M12 8.8	90 Nm
BK2-500 kg	15.9	M12 8.8	90 Nm
BK2-1000 kg	19.1	M12 8.8	90 Nm
BK2-2000 kg	25.4	M12 10.9	120 Nm

**Torque values assume oiled threads.

wiring

The load cell is provided with a shielded, 4 conductor cable (AWG 24).

Cable jacket: polyurethane

Cable length: 3 m

Cable diameter: 5 mm

The shield is floating

(On request the shield can be connected to the load cell body)

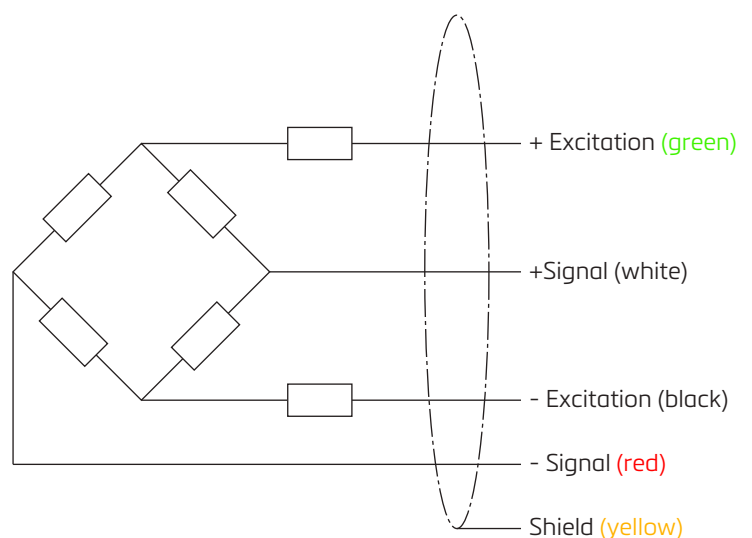

Specifications and dimensions are subject to change without notice.