

- Type:** Single Point
- Material:** Aluminum Alloy
- Surface:** Anodized Treatment
- Protection:** IP 65
- Features:** Suggested Platform
Size: 250 x 350 mm
- Application:** Bench & Counting Scales
Bagging Machine
Check Weigher



Specifications:

Capacity		3kg / 5kg / 6kg / 10kg / 15kg / 20kg / 30kg / 35kg / 40kg / 50kg	
Accuracy Class		C3	C5
Max. Number of Verification Intervals	n_{max}	3000	5000
Minimum Load Cell Verification Level	V_{min}	$E_{max}/10000$	$E_{max}/20000$
Temperature Effect on Zero	%FS/10°C	$\leq \pm 0.0205$	$\leq \pm 0.0090$
Temperature Effect in Sensitivity	%FS/10°C	$\leq \pm 0.0178$	$\leq \pm 0.0115$
Combined Error	%FS	$\leq \pm 0.0200$	$\leq \pm 0.0120$
Creep	%FS	$\leq \pm 0.0170$	$\leq \pm 0.0148$
Output Sensitivity	mv/v	2.0 ± 0.1	
Input Resistance	Ω	410 ± 5	
Output Resistance	Ω	350 ± 3.5	
Insulation Resistance	M Ω	≥ 5000	
Zero Balance	%FS	≤ 2.0	
Temperature, Compensated	°C	$-10 \sim +40$	
Temperature, Operating	°C	$-20 \sim +50$	
Excitation, Recommended	v	$5 \sim 15$	
Safe Overload	%FS	150	
Ultimate Overload	%FS	300	
Standard Cable length	m	0.45	

Dimensions:

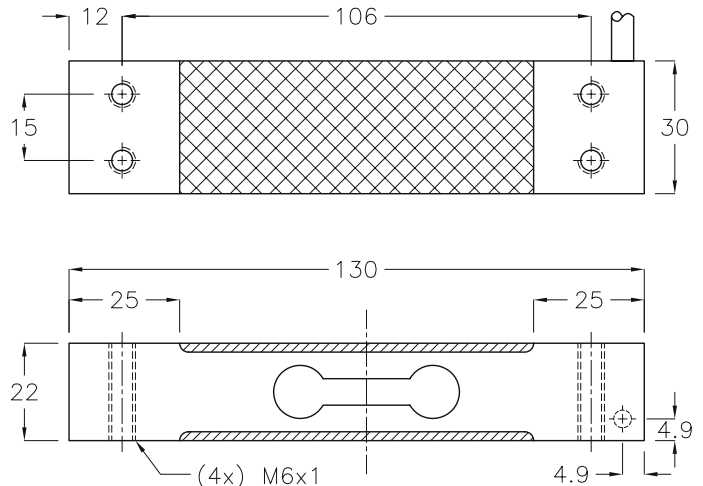
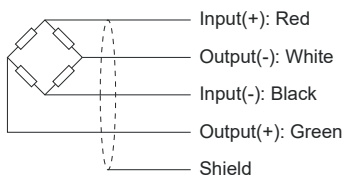

All dimensions: mm.