

Type: Loadcell Mounting (for BSQ)

Material: Stainless Steel

Features: Lift-off Protection
Self-aligning construction
Easy load cell access

Application: Pallet Scales
Hopper Scales
Process Weighing
Overhead Track

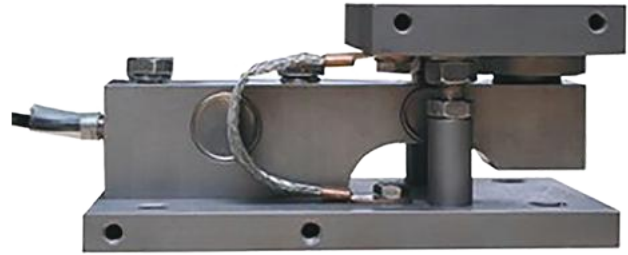

Specifications:

Capacity		500kg / 1.0t / 2.0t	5.0t / 7.5t / 10t
Maximum vertical force (down)	kN	15	40
Maximum vertical force (up)	kN	10	25
Maximum horizontal force	kN	5	12
Maximum horizontal movement	mm	± 2	± 2

Dimensions:

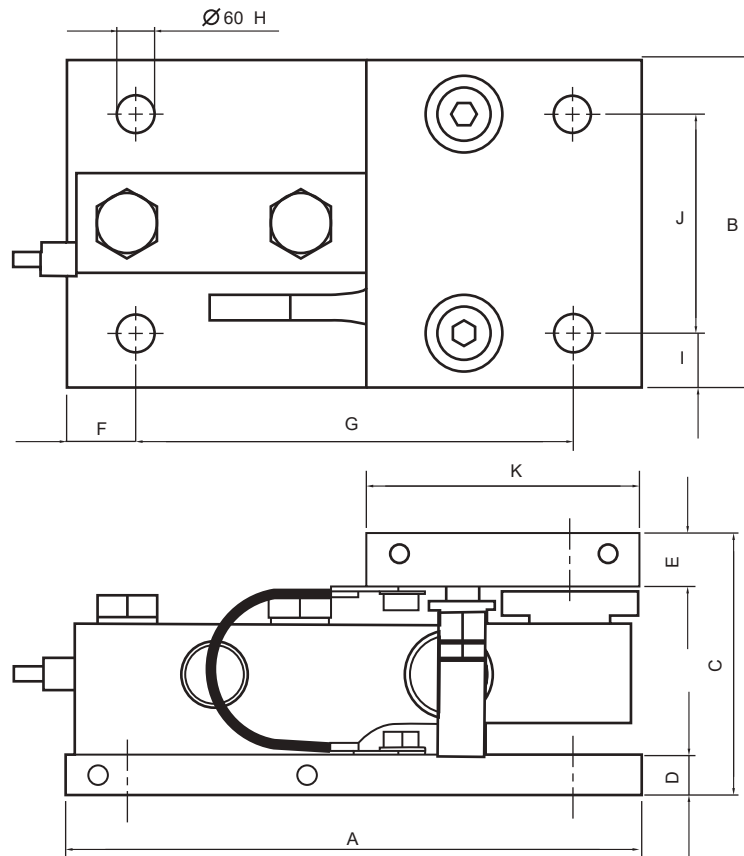

CAP.(t)	A	B	C	D	E	F	G	H	I	J	K
0.5-2t	210	120	96	15	20	25	160	14	20	80	100
5-7,5t	250	150	138	20	20	25	200	18	25	100	120
10t	260	150	153	20	30	25	210	18	25	100	130

All dimensions: mm.